



**Model No. 30.7212**  
**Speaker Mounting Bracket**  
**FOR**  
**2000 - 2005 Chevrolet IMPALA**

**INSTALLATION INSTRUCTIONS**

**30.7212** Speaker Mounting Bracket allows a standard siren speaker driver to be mounted behind the grille of a 2000-05 Impala without any drilling. Bracket will allow speaker to mount in a horizontal position for maximum sound performance. Estimated installation time: 10 minutes.

**INSTRUCTIONS:**

1. Open the hood.
2. Remove the black plastic cover in front of the radiator by removing the three black plastic push-in style rivets.
3. After removing the black plastic cover, notice the black wire loom attached to the back side of the front bumper on the driver's side. Detach the loom from the bumper.
4. Notice the four large round holes in the plate on the back side of the bumper where the loom was attached. Slide each of the flat plates provided (with the two  $\frac{1}{4}$ " bolt studs) through the slots of the bumper with the studs facing through the large round holes.
5. Mount the speaker driver on the back side of the speaker bracket. The bolts should go in from the front side of the bracket.
6. Set a low-profile style speaker cone and tip on top of the bumper behind the grille and slide it out of the way for now!
7. Mount the speaker bracket to the four studs that face through the four large holes, using the Kepps nuts and washers provided. Do Not Completely Tighten Yet. (This allows adjustment while installing cone and tip.)
8. Remove the three plastic push-in rivets from the top of the grille and remove one plastic push-in rivet with rubber bumper from between the grille and the driver's side headlight.
9. Bend the grille back. Slide the cone onto the speaker driver and screw on the tip.
10. Now tighten the four nuts on the four studs to securely attach the bracket to the bumper.
11. Replace the plastic push-in rivets and re-mount the plastic cover in front of the radiator. Installation is now complete.



**PRODUCTS COMPANY** 804 East Hwy 248 Cassville, MO 65625  
U.S. and Canada Toll Free Numbers Phone: 800-641-4098 FAX: 800-526-1240  
E-mail: sales@able2products.com WEB: www.able2products.com

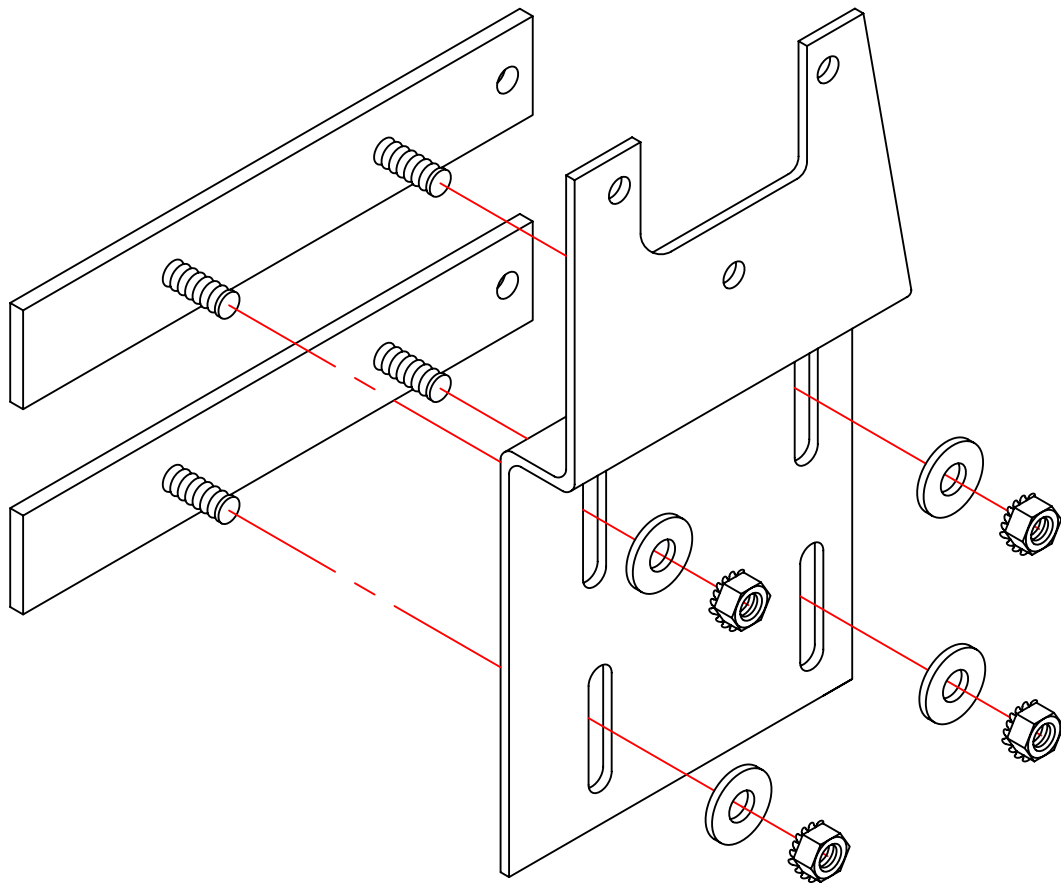

**LIMITED WARRANTY**

Able 2 Products Company warrants each new product (except bulbs, strobe tubes, strobe power supplies and LED Products) to be free from defects in material and workmanship for a period of two years from the date of purchase. During this warranty period, the obligation of Able 2 is limited to repairing or replacing, as Able 2 may elect, any part or parts, which after examination by Able 2 are determined to be defective, when they are delivered pre-paid. This limited warranty does not cover travel expense, the cost of specialized equipment for gaining access to the product, or labor charges for the removal and re-installation of the product.

Able 2 Products Company shall not be liable for incidental or consequential damages, including but not limited to : Loss of use of vehicle, Rental of substitute vehicle, Loss of time, Loss of work, Inconvenience, Transportation expenses, Telephone, Lodging, Loss of revenue, Loss of and /or damage to personal property for or arising out of breach of any express or implied warranty of its products.

Use of lamp or other electrical load of a wattage higher than installed or recommended by the factory, or use of inappropriate or inadequate wiring or circuit protection causes this limited warranty to become void. Able 2 Products Company will in no way be liable for any loss of profits or any indirect or consequential damages arising out of any such defect in material and workmanship whether loss is due to negligence or breach of warranty. This limited warranty does not apply to shipping damage, accident, alteration, tampering, misuse or abuse and unauthorized service.

This limited warranty is expressly in lieu of all other express or implied warranties, including the implied warranty of merchantability and the implied warranty of fitness for a particular purpose, and of all other obligations or liabilities on the part of Able 2 Products Company. There are no warranties, unless expressed in authorized Able 2 literature, which extend beyond the description of the face hereof. No dealer, distributor, employee, or representative of the company is authorized to change this warranty in any way or to grant any other warranty.

<b>WARRANTIES:</b>	All LED Products . . . . .	5 Years
	T Model & Potted Strobe Power Supplies	2 Years
	All Other Strobe Power Supplies . . . . .	5 Years
	All Other Products EXCEPT Bulbs . . . . .	2 Years (under normal use)
	Strobe Tubes . . . . .	1 Year (under normal use)
	NOTE: Halogen and Incandescent Bulbs are not covered by warranty.	

**PRODUCT RETURNS**

If a product must be returned, contact our factory by calling 1-800-641-4098 to obtain a Return Authorization Number (RA) before you ship the product. Write the RA Number clearly on the package and return it to Able 2 Products Company, P.O. Box 543, 804 E. Hwy. 248, Cassville, MO 65625-0543. A packing slip should be included with all shipments listing the sender's name, address, daytime phone number and description of defect. Your product will be put in first-class operating condition or replaced with a new part, and returned pre-paid.