

# SHO-ME<sup>®</sup> MICROTHIN

## WIDE ANGLE REMOTE STROBE HEAD

MODEL NO. 20.1850

### ELECTRICAL SPECIFICATIONS:

**Maximum Power Rating:** 20 Watts  
**Maximum Energy Discharge:** 22 Joules.  
**Operating Voltage:** 225Vdc Min, 650Vdc Max.

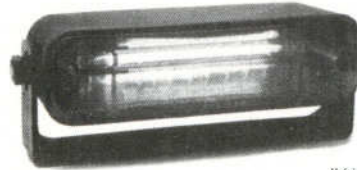

Made in  
the United  
States of  
America

### INSTALLATION:

#### Mounting:

Mount the bracket to the vehicle in the desired location using the screws provided. Attach The Microthin to the bracket using the two 7/16" bolts and lock-washers provided.

The Microthin can be mounted to a horizontal or vertical surface and can be aimed on many directions. Do not mount the Microthin with the lens pointing straight up as this may cause the lens to overheat.

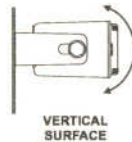

#### Connect to Power Supply:

Route the cable through the vehicle body and plug into the Strobe Power Supply.

The shield wire may also be connected to *chassis ground* to reduce RFI.

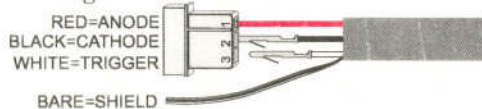

### FLASHTUBE REPLACEMENT:

REPLACEMENT TUBE PART #: 20.1880

Remove the two screws which hold the lens to the body of the strobe head. Remove the lens and pull out the flashtube/reflector assembly. Disconnect the flashtube/reflector from the two connectors on the cable and plug in the new one. Re-assembly is the reverse of the above.

### DIMENSIONS:

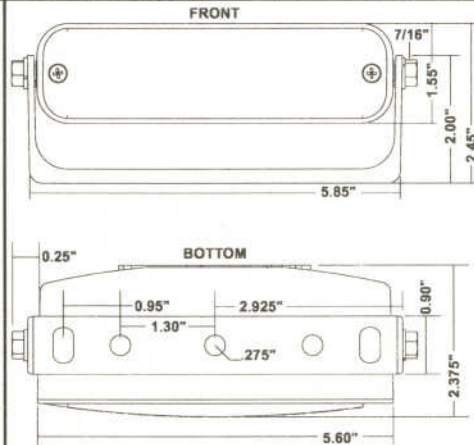

### REPLACEMENT PARTS:

PART NUMBER:	DESCRIPTION
20.1880	REPLACEMENT FLASHTUBE/REFLECTOR
20.1885.A00	AMBER LENS
20.1885.B00	BLUE LENS
20.1885.C00	CLEAR LENS
20.1885.G00	GREEN LENS
20.1885.P00	PURPLE LENS
20.1885.R00	RED LENS

### LIMITED WARRANTY

Able 2 Products Company warrants each new product (except bulbs and strobe tubes) to be free from defects in material and workmanship for a period of two years from the date of purchase. During this warranty period, the obligation of Able 2 is limited to repairing or replacing, as Able 2 may elect, any part or parts, which after examination by Able 2 are determined to be defective, when they are delivered pre-paid. This limited warranty does not cover travel expense, the cost of specialized equipment for gaining access to the product, or labor charges for the removal and re-installation of the product.

Able 2 Products Company shall not be liable for incidental or consequential damages, including but not limited to: Loss of use of vehicle, Rental of substitute vehicle, Loss of time, Loss of work, Inconvenience, Transportation expenses, Telephone, Lodging, Loss of revenue, Loss of and/or damage to personal property for or arising out of breach of any express or implied warranty of its products.

Use of lamp or other electrical load of a wattage higher than installed or recommended by the factory, or use of inappropriate or inadequate wiring or circuit protection causes this limited warranty to become void. Able 2 Products Company will in no way be liable for any loss of profits or any indirect or consequential damages arising out of any such defect in material and workmanship whether loss is due to negligence or breach of warranty. This limited warranty does not apply to shipping damage, accident, alteration, tampering, misuse or abuse and unauthorized service.

This limited warranty is expressly in lieu of all other express or implied warranties, including the implied warranty of merchantability and the implied warranty of fitness for a particular purpose, and of all other obligations or liabilities on the part of Able 2 Products Company. There are no warranties, unless expressed in authorized Able 2 literature, which extend beyond the description of the face hereof. No dealer, distributor, employee, or representative of the company is authorized to change this warranty in any way or to grant any other warranty.

### PRODUCT RETURNS

If a product must be returned, contact our factory by calling 1-800-641-4098 to obtain a Return Authorization Number (RA) before you ship the product. Write the RA Number clearly on the package and return it to Able 2 Products Company, P.O. Box 543, 804 E. Hwy. 248, Cassville, MO 65625-0543. A packing slip should be included with all shipments listing the sender's name, address, daytime phone number and description of defect. Your product will be put in first-class operating condition or replaced with a new part, and returned pre-paid.

**WARRANTIES:** Strobe Power Supplies ..... .5 Years  
All Other Products (EXCEPT Bulbs) ..... .2 Years (under normal use)  
Strobe Tubes ..... .1 Year (under normal use)  
NOTE: Halogen and Incandescent Bulbs are not covered by warranty.

*Revised February 2004*