



LIGHT STORM[®] LED Warning Stick Model No. 12.6104

GENERAL INFORMATION

The 12.6104 Light has 39 flash patterns. To change flash pattern, momentarily apply +12v to white mode wire. Each time +12v is applied, the flash pattern will change. To set Default Random flash pattern apply +12v to white wire for more than 5 seconds. The flash patterns are:

- | | | | |
|---------------------|---------------------------|---------------------------|-----------------------------|
| 1. Alt 120 1,2-3,4 | 11. Sim 600 | 21. Double-On Sim | 31. Scan Slow |
| 2. Alt 120 1,3-2,4 | 12. Sim 1200 | 22. Quad-On Alt 1,2-3,4 | 32. Scan Slow Double |
| 3. Alt 240 1,2-3,4 | 13. Double Alt 1,2-3,4 | 23. Quad-On Alt 1,3-2,4 | 33. Scan Fast |
| 4. Alt 240 1,3-2,4 | 14. Double Alt 1,3-2,4 | 24. Quad-On Sim | 34. Scan Fast Double |
| 5. Alt 600 1,2-3,4 | 15. Double Sim | 25. Fast-Slow Alt 1,2-3,4 | 35. Scan-Mega |
| 6. Alt 600 1,3-2,4 | 16. Quad Alt 1,2-3,4 | 26. Fast-Slow Alt 1,3-2,4 | 36. Random All 35 (Default) |
| 7. Alt 1200 1,2-3,4 | 17. Quad Alt 1,3-2,4 | 27. Fast-Slow Sim | 37. Random Alt 20 |
| 8. Alt 1200 1,3-2,4 | 18. Quad Sim | 28. Mega-On Alt 1,2-3,4 | 38. Random Sim 10 |
| 9. Sim 120 | 19. Double-On Alt 1,2-3,4 | 29. Mega-On Alt 1,3-2,4 | 39. Random Seq 5 |
| 10. Sim 240 | 20. Double-On Alt 1,3-2,4 | 30. Mega-On Sim | |

INSTALLATION INSTRUCTIONS

Use the L - brackets (included) to mount the 12.6104 light. To install mounting bolts to the warning stick, remove the 4 screws from the end cap and install the mounting bolts into the desired t-slot as shown in drawing. Re-install the end cap.

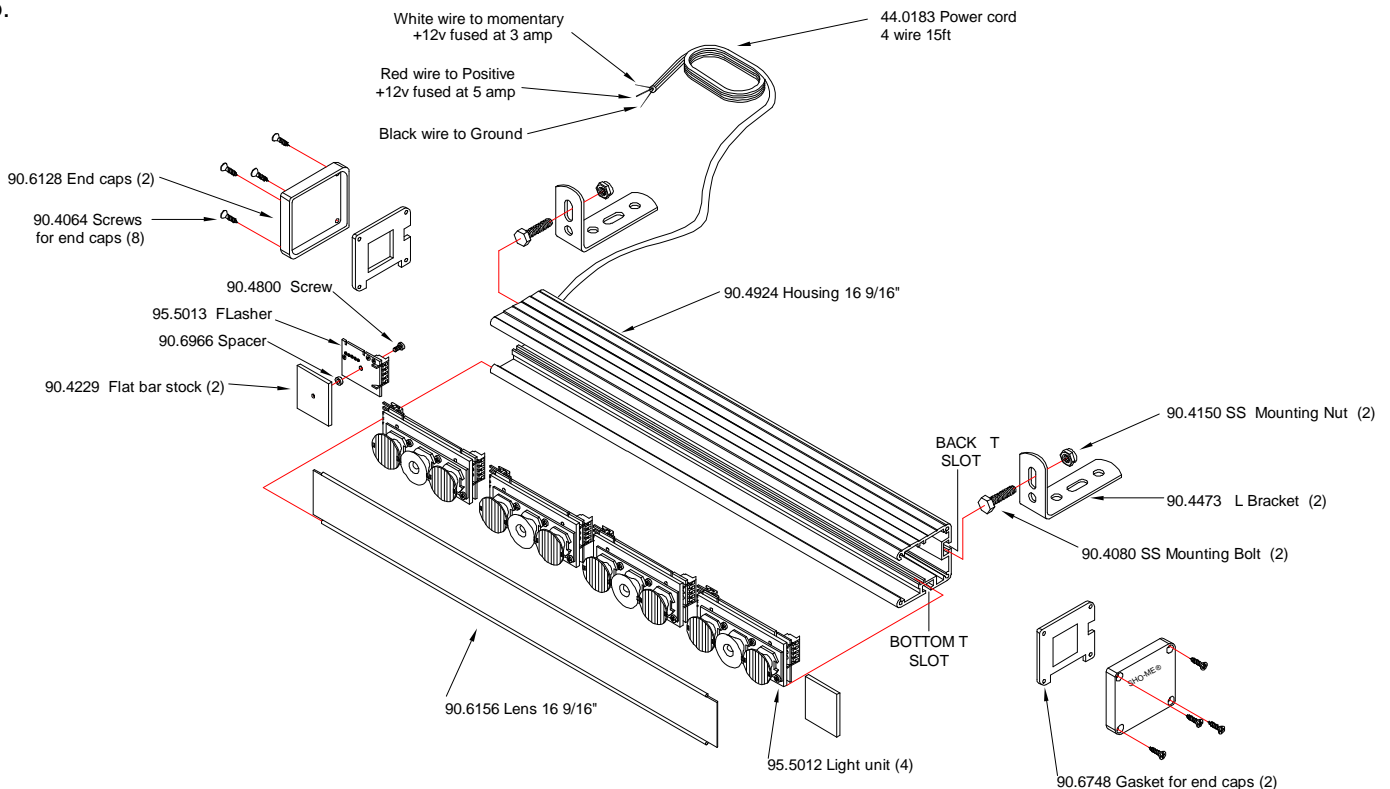

PRODUCTS COMPANY • 804 East Hwy. 248 • Cassville, MO 65625
U.S. and Canada Toll Free Numbers • Phone: 800-641-4098 FAX: 800-526-1240
E-mail: sales@able2products.com WEB: www.able2products.com