



LIGHT STORM[®]
LED Warning Stick
MODEL NO. 12.6103S

GENERAL INFORMATION

The 12.6103S Light has 27 flash patterns. To change flash pattern, press the momentary switch **(Located on the lighter plug adaptor)**. Each time the momentary switch is pressed, the flash pattern will change. To set Default Random flash pattern **press and hold** momentary switch for more than 5 seconds. The flash patterns are:

- | | | | |
|-------------|-------------------|-------------------|----------------|
| 1. Alt 120 | 8. Sim 1200 | 15. Quad-On Alt | 22. Scan Fast |
| 2. Alt 240 | 9. Double Alt | 16. Quad-On Sim | 23. Scan-Mega |
| 3. Alt 600 | 10. Double Sim | 17. Fast-Slow Alt | 24. Random All |
| 4. Alt 1200 | 11. Quad Alt | 18. Fast-Slow Sim | 25. Random Alt |
| 5. Sim 120 | 12. Quad Sim | 19. Mega-On Alt | 26. Random Sim |
| 6. Sim 240 | 13. Double-On Alt | 20. Mega-On Sim | 27. Random Seq |
| 7. Sim 600 | 14. Double-On Sim | 21. Scan slow | |

INSTALLATION INSTRUCTIONS

Use the L - brackets (included) to mount the 12.6103S light. To install mounting bolts to the warning stick, remove the screws from the end cap and install the mounting bolts into the desired t-slot as shown in drawing. Re-install the end cap.

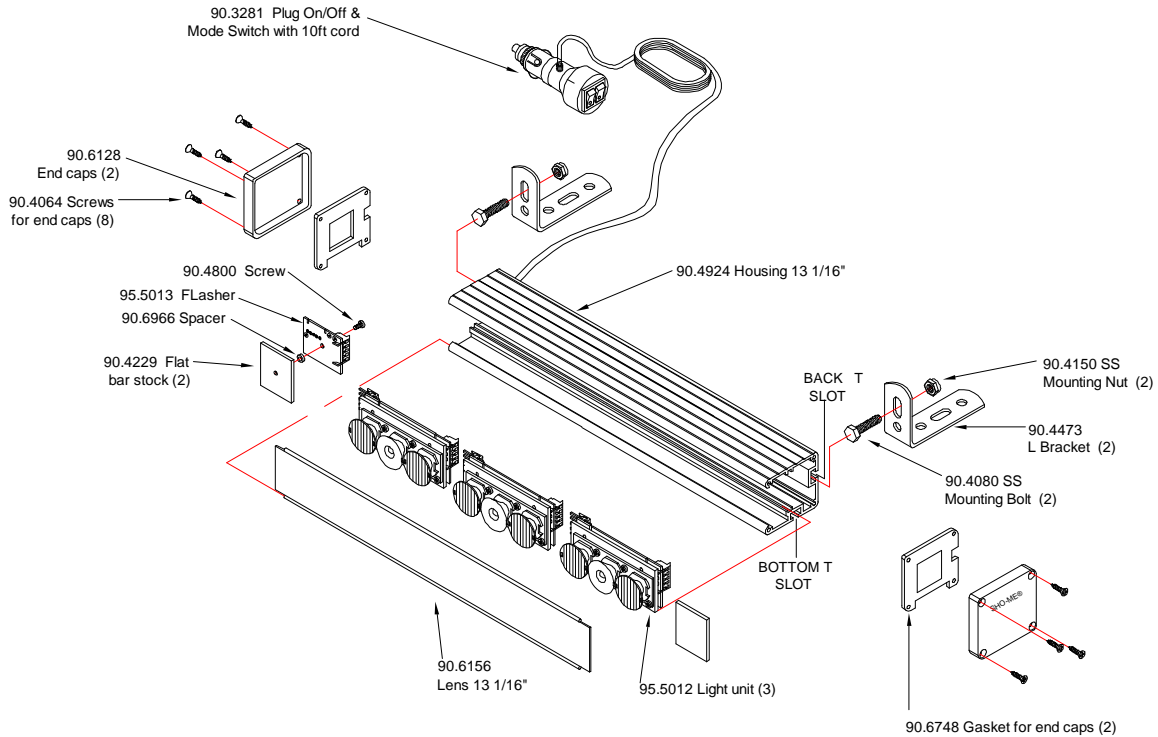

PRODUCTS COMPANY • 804 East Hwy. 248 • Cassville, MO 65625
U.S. and Canada Toll Free Numbers • Phone: 800-641-4098 FAX: 800-526-1240
E-mail: sales@able2products.com WEB: www.able2products.com