



# MODEL NO. 12.5004 Luminator LED Quad Light

## **General Information:**

The Luminator LED Quad Light is equipped with an internal flasher. It comes from the factory in a random flash mode.

## **Wiring Instructions:**

When wiring, **Always** connect ground wire first and power wire last.

## **Group Selection:**

The White "Group Selection" Wire will determine which lights flash at the same time, when you have 2 or more lights.

For Group 1, connect White "Group Selection" wire with Red Power wire.

For Group 2, DO NOT connect White "Group Selection" wire to anything.

Group 1 & Group 2 will alternate.

**\*Do Not** use White wire if using only one light.\*

## **Flash Pattern Selection:**

To change flash patterns, momentarily apply +12v to the Yellow "Sync-Mode" Wire. To reset to factory default pattern, apply +12v to the Yellow "Sync-Mode" Wire for more than 5 seconds. **\*Do Not** ground **YELLOW** Wire.\*

### **Flash Patterns**

- |                             |                                   |  |
|-----------------------------|-----------------------------------|--|
| 1. Single simultaneous      | 10. Random 1-8, all simultaneous  | <b>Note:</b> To use patterns 20-29 apply +12v to the yellow wire for more than 30 seconds. |
| 2. Double simultaneous      | 11. Single alternate              |  |
| 3. Quad simultaneous        | 12. Double alternate              |  |
| 4. Oct Simultaneous         | 13. Quad alternate                |  |
| 5. Double - On simultaneous | 14. Oct alternate                 |  |
| 6. Quad - On simultaneous   | 15. Double - On alternate         |  |
| 7. Triple simultaneous      | 16. Quad - On alternate           |  |
| 8. 12 Flash simultaneous    | 17. Triple alternate              |  |
| 9. Steady simultaneous      | 18. 12 Flash alternate            |  |
|                             | 19. Random 11-18, all alternating |  |
|                             | 20. Steady - Single               |  |
|                             | 21. Steady - Double               |  |
|                             | 22. Steady - Quad                 |  |
|                             | 23. Steady - Oct                  |  |
|                             | 24. Steady - Double - On          |  |
|                             | 25. Steady - Quad - On            |  |
|                             | 26. Steady - Triple               |  |
|                             | 27. Steady - 12 Flash             |  |
|                             | 28. Random 20-27, 1 side steady   |  |
|                             | 29. Random All 1-8, 11-18, 20-27  |  |

## **Product Specifications:**

Optimum Operation Voltage: +13.8 VDC  
Operating Current: .75-1.5 amps  
Recommended Fuse: 5 amp

## **Installation Instructions**

### **Luminator LED Quad Light Installation**

Use Point A. Drill the 2 holes on the mounting surface for the Luminator LED Quad Light using the Quad Light as a guide. Place the gasket under the Quad Light. Attach the Quad Light using (2) screws #90.4025.



**PRODUCTS COMPANY - 804 East Hwy. 248 - Cassville, MO 65625**  
**U.S. and Canada Toll Free Numbers - Phone: 800-641-4098 FAX: 800-526-1240**  
**E-mail: sales@able2products.com WEB: www.able2products.com**

# Wiring Multiple Light Heads

## Synchronize:

To synchronize multiple light heads, connect all yellow wires together, then touch yellow wires to +12v for more than five seconds to put them into the same pattern.

All light heads will be synchronized and flash simultaneously.

To alternate light heads see (Group Selection) below.

## Group Selection:

The White "Group Selection" Wire will determine which lights flash at the same time, when you have 2 or more lights.

For Group 1, connect White "Group Selection" wire with Red Power wire.

For Group 2, DO NOT connect White "Group Selection" wire to anything.

Group 1 & Group 2 will alternate.

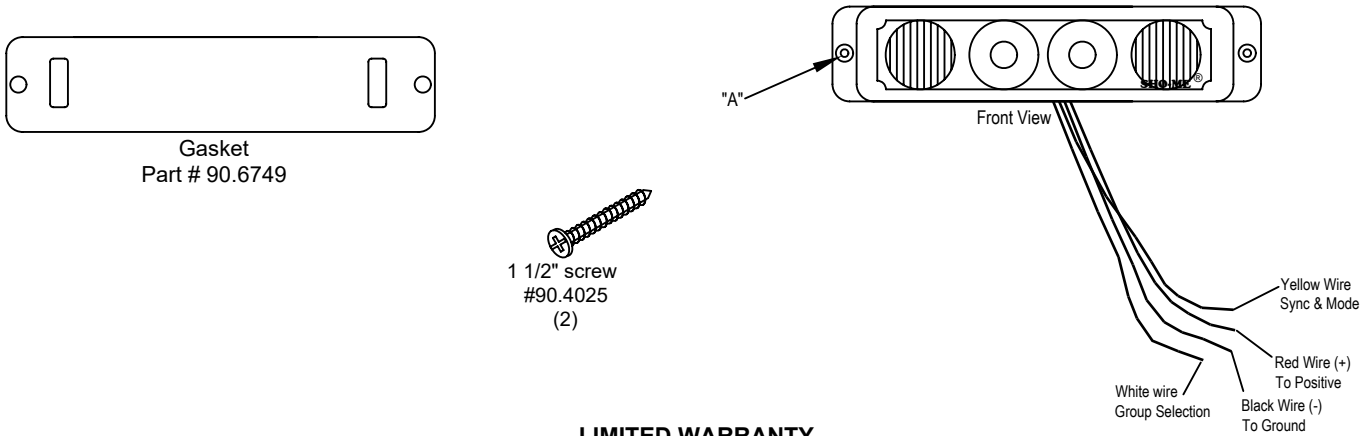

### LIMITED WARRANTY

Able 2 Products Company warrants each new product (except bulbs, strobe tubes and strobe power supplies and LED lights) to be free from defects in material and workmanship for a period of two years from the date of purchase. During this warranty period, the obligation of Able 2 is limited to repairing or replacing, as Able 2 may elect, any part or parts, which after examination by Able 2 are determined to be defective, when they are delivered pre-paid. This limited warranty does not cover travel expense, the cost of specialized equipment for gaining access to the product, or labor charges for the removal and re-installation of the product.

Able 2 Products Company shall not be liable for incidental or consequential damages, including but not limited to: Loss of use of vehicle, Rental of substitute vehicle, Loss of time, Loss of work, Inconvenience, Transportation expenses, Telephone, Lodging, Loss of revenue, Loss of and/or damage to personal property for or arising out of breach of any express or implied warranty of its products.

Use of lamp or other electrical load of a wattage higher than installed or recommended by the factory, or use of inappropriate or inadequate wiring or circuit protection causes this limited warranty to become void. Able 2 Products Company will in no way be liable for any loss of profits or any indirect or consequential damages arising out of any such defect in material and workmanship whether loss is due to negligence or breach of warranty. This limited warranty does not apply to shipping damage, accident, alteration, tampering, misuse or abuse and unauthorized service.

This limited warranty is expressly in lieu of all other express or implied warranties, including the implied warranty of merchantability and the implied warranty of fitness for a particular purpose, and of all other obligations or liabilities on the part of Able 2 Products Company. There are no warranties, unless expressed in authorized Able 2 literature, which extend beyond the description of the face hereof. No dealer, distributor, employee, or representative of the company is authorized to change this warranty in any way or to grant any other warranty.

### WARRANTY PERIODS

Select LED Products .....	5 Years	T Model & Potted Strobe Power Supplies .....	2 Years
10 Series LED Products .....	2 Years	All Other Strobe Power Supplies .....	5 Years
Covert LEDs.....	2 Year	Strobe Tubes (under normal use).....	1 Year
11.8400 Series LED Lights.....	1 Years	All Other Products EXCEPT Bulbs (under normal use).....	2 Years

NOTE: Halogen and Incandescent Bulbs are not covered by warranty.

### PRODUCT RETURNS

If a product must be returned, contact our factory by calling 1-800-641-4098 to obtain a Return Authorization number (RA) before you ship the product. Write the RA Number clearly on the package and return it to Able 2 Products Company, P.O. Box 543, 804 E. Hwy. 248, Cassville, MO 65625- 0543. A packing slip should be included with all shipments listing the sender's name, address, daytime phone number and description of defect. Your product will be put in first-class operating condition or replaced with a new part, and returned pre-paid.