

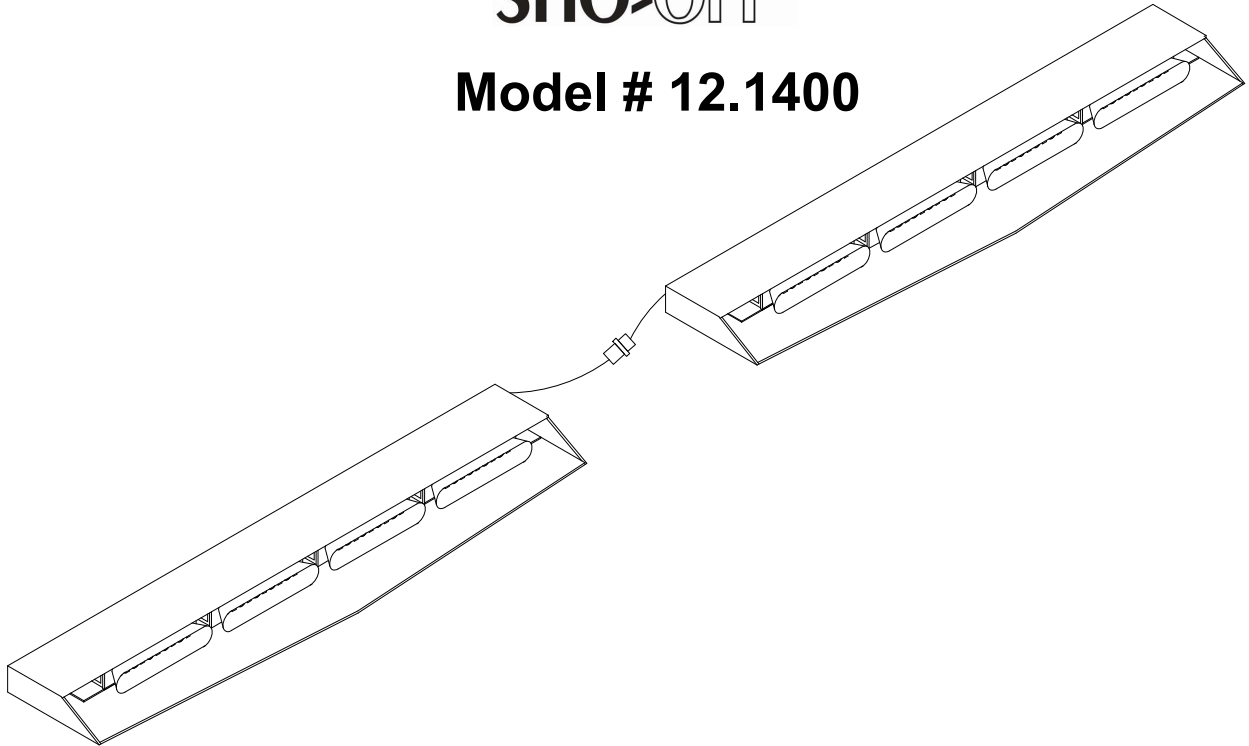

SHO-OFF[®]

Model # 12.1400



General Information

The NEW Sho-Off Insider interior LED light bar is one of the smallest and brightest on the market today. Installation is simple with our NEW "Slip-Liner", "No Holes Drilled" brackets.

Eight LED modules with 48 ultra-bright 3w leds total. Slim housing under 1" high, permits unobstructed view. Internal flasher.

Dimensions:

$\frac{3}{4}$ "H x 16"L x $3\frac{1}{2}$ " D (each light)

Maximum Amp Draw 5 amps

Made in the U.S.A.

2 Year NO Hassle Warranty

Standard Flash Patterns

Random

Wig Wag

Scan

Alternating 2-2

Quad Simultaneous

Crossfire

Double Simultaneous

Alternating 1-3-5-7 / 2-4-6-8

Single Simultaneous



PRODUCTS COMPANY • 804 East Hwy. 248 • Cassville, MO 65625

U.S. and Canada Toll Free Numbers • Phone: 800-641-4098 FAX: 800-526-1240

E-mail: sales@able2products.com WEB: www.able2products.com

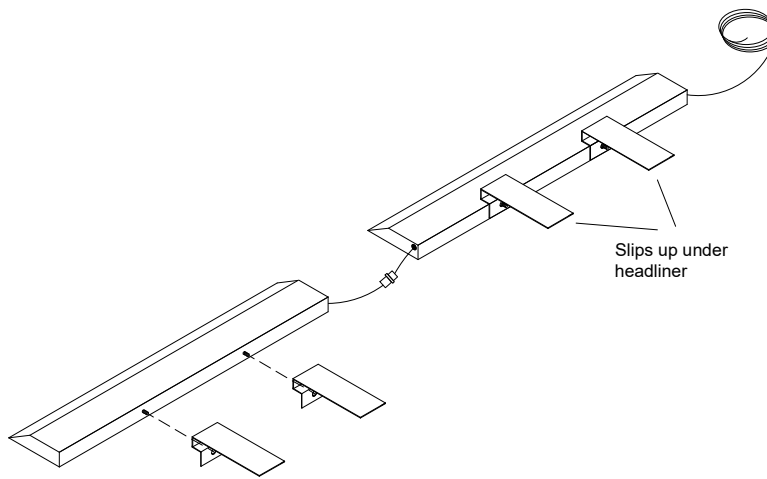

Installation:

Your new Insider LED interior light bar mounts to the headliner, using the Slip-Liner brackets. Determine the desired location along the upper portion of the windshield or back deck. Do not mount in Driver's or Passenger Side Air Bag deployment zones. Any device mounted in the deployment area of an air bag will damage or reduce the effectiveness of the air bag and may damage or dislodge the device.

Slip the Slip-Liner bracket up under the headliner. The bracket is made of a malleable aluminum that will allow you to bend the bracket slightly. Due to the windshield angle, each bracket may need bent slightly different. After bending the brackets, attach them to the lights using the hardware provided. You can now install the lights to the headliner. When installed correctly, the front of the Insider Light Bar should be as close to the windshield as possible. After mounting, adjust the front Glare Shields to cover any gap between the light and windshield. Place the small square piece of 3M[®] tape provided between the Glare Shield and Light Housing to hold it in place. Attach foam strips to front and sides of Insider Light Bar where required to block any flash back.

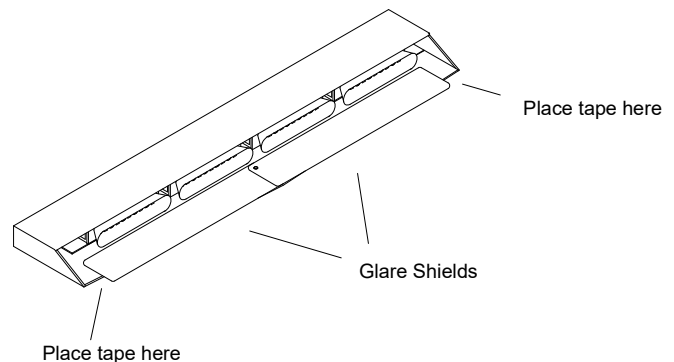

Wiring:

Connect two Insider Light bars together with (2) amp connectors. Route your wiring keeping in mind Airbag zones. Wire according to the diagram below.

