

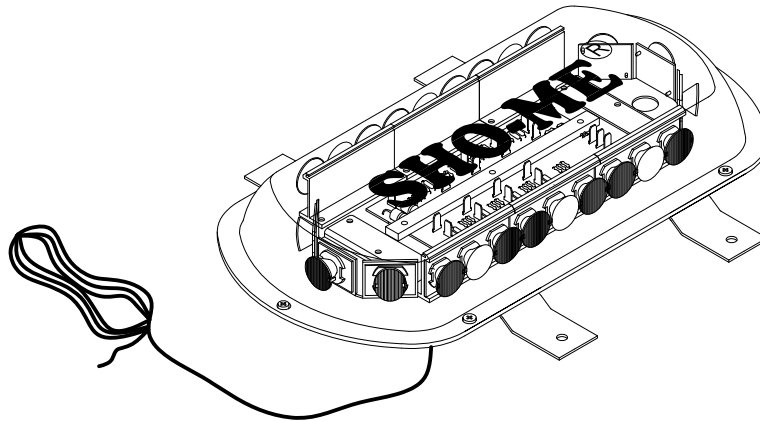

MODEL NO. 12.1224
Permanent Mount
Luminator LED Mini Bar



GENERAL INFORMATION:

The **SHO-ME** Luminator LED Mini Bar is equipped with a solid state LED flasher. The LED flasher has 12 flash patterns including random. A momentary switch is required to change flash pattern (not included). Each time the momentary switch is pressed, the flash pattern will change. To go directly to random, press the momentary mode switch for more than 5 seconds.

WIRING INSTRUCTIONS:

Connect the Green wire to positive +12 volts switched.
Connect the White wire to positive +12 volts momentary switched.
Connect the Black wire to Ground.

FLASH PATTERNS

Quad Flash	Single Flash Fast
Chase	Fade
Scan	Crossfire
Quad Alternate	Quad Quad Single
Single Flash Slow	Double Flash
Single Flash Medium	Random

INSTALLATION INSTRUCTIONS:

Determine location to mount your Luminator LED Mini Light Bar. Do not install this product or route any wires in the deployment area of your air bag. Equipment mounted or located in the air bag deployment area will damage or reduce the effectiveness of the air bag, or become a projectile that could cause serious personal injury or death.

If mounting this product requires drilling holes, the installer MUST be sure that no vehicle components or other vital parts could be damaged by the drilling process. Check both sides of the mounting surface before drilling begins. Also de-burr any holes and remove any metal shards or remnants. Install grommets into all wire passage holes.

Use only soap and water to clean the outer lens. Use of other chemicals could result in premature lens cracking and discoloration. Lenses in this condition have significantly reduced effectiveness. Inspect and operate this product regularly to confirm its proper operation and mounting condition. **Do not use a pressure washer to clean this product.**



PRODUCTS COMPANY • 804 East Hwy. 248 • Cassville, MO 65625
U.S. and Canada Toll Free Numbers • Phone: 800-641-4098 FAX: 800-526-1240
E-mail: sales@able2products.com WEB: www.able2products.com

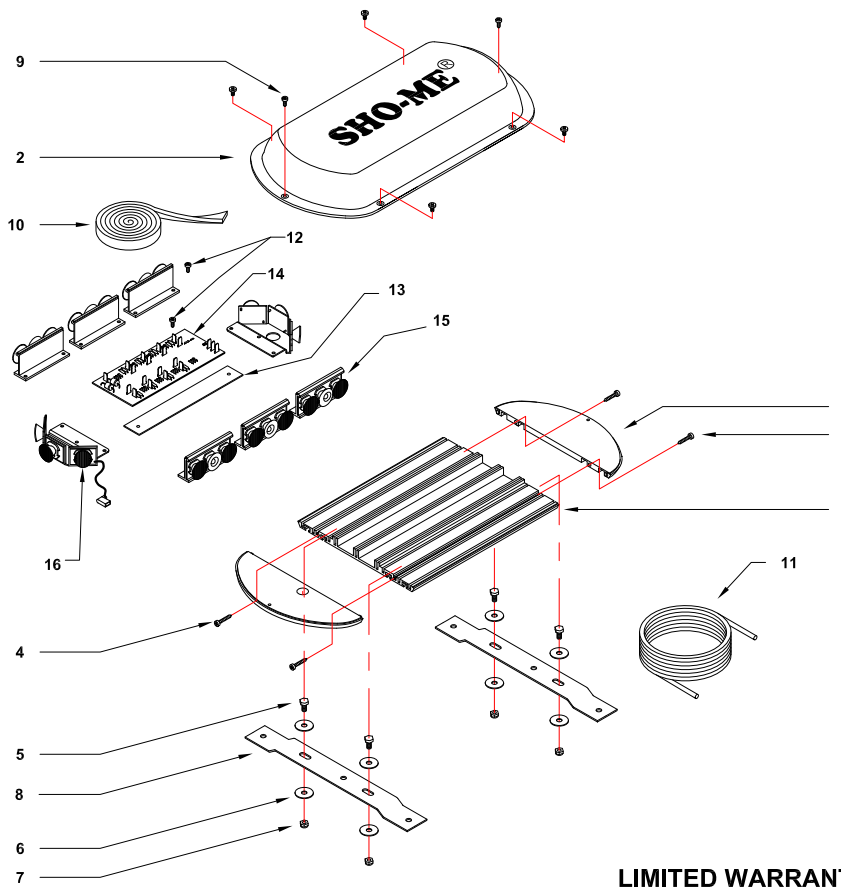

Parts List for 12.1224.000
Luminator LED Mini Bar Permanent Mount

ITEM	MODEL NO.	DESCRIPTION	QTY
1	90.4986	Main Alu Extrusion	1
2	90.6127.C00	Clear Lexan Cover	1
3	90.6125	Black Plastic Endcaps	2
4	90.4018.SS	#8x 1" RD Head Phil s/m	4
5	90.4490	1/4 -20 X 1/ 2 Hex Hd Bolt SS	4
6	90.4522	1/ 4 x 1 Fender washer 18-8 SS	8
7	90.4150	1/ 4 -20 Nylon Insert L/N NTE SS	4
8	90.4958	Brkts/Stealth 15 GA SS	2
9	90.4002	#8 X 1/ 2 812 Self Tapping Screw	6
10	90.6039.	1/ 8" X 3/ 4" Black Foam Adhesive 4'	1
11	90.3277	Power Cable 3 Wire 15 ft w/grommet	1
12	90.4720SS	8mm screws 8-32x3/8 SS	20
13	90.6680	Hard Paper	1
14	95.5008	Pc board Main	1
15	12.9570	Luminator side section complete	6
16	12.9580	Luminator end section complete	2

LIMITED WARRANTY

Able 2 Products Company warrants each new product (except bulbs, strobe tubes and strobe power supplies) to be free from defects in material and workmanship for a period of two years from the date of purchase. During this warranty period, the obligation of Able 2 is limited to repairing or replacing, as Able 2 may elect, any part or parts, which after examination by Able 2 are determined to be defective, when they are delivered pre-paid. This limited warranty does not cover travel expense, the cost of specialized equipment for gaining access to the product, or labor charges for the removal and re-installation of the product.

Able 2 Products Company shall not be liable for incidental or consequential damages, including but not limited to : Loss of use of vehicle, Rental of substitute vehicle, Loss of time, Loss of work, Inconvenience, Transportation expenses, Telephone, Lodging, Loss of revenue, Loss of and /or damage to personal property for or arising out of breach of any express or implied warranty of its products.

Use of lamp or other electrical load of a wattage higher than installed or recommended by the factory, or use of inappropriate or inadequate wiring or circuit protection causes this limited warranty to become void. Able 2 Products Company will in no way be liable for any loss of profits or any indirect or consequential damages arising out of any such defect in material and workmanship whether loss is due to negligence or breach of warranty. This limited warranty does not apply to shipping damage, accident, alteration, tampering, misuse or abuse and unauthorized service.

This limited warranty is expressly in lieu of all other express or implied warranties, including the implied warranty of merchantability and the implied warranty of fitness for a particular purpose, and of all other obligations or liabilities on the part of Able 2 Products Company. There are no warranties, unless expressed in authorized Able 2 literature, which extend beyond the description of the face hereof. No dealer, distributor, employee, or representative of the company is authorized to change this warranty in any way or to grant any other warranty.

WARRANTY PERIODS

- 11, 12 & 13 Series LED Products*2 Years
- *11.8400 Series LED Lights.....1 Year
- *12 Series Covert LEDs.....1 Year
- 10 Series LED Lights1 Year
- 09 Zoom Lite / 06 Series LED Lights.....1 Year
- All Other Products EXCEPT T BULBS (under normal use) 1 Year

NOTE: Halogen and Incandescent Bulbs are not covered by warranty.

PRODUCT RETURNS

If a product must be returned, contact our factory by calling 1-800-641-4098 to obtain a Return Authorization Number (RA) before you ship the product. Write the RA Number clearly on the package and return it to Able 2 Products Company, P.O. Box 543, 804 E. Hwy. 248, Cassville, MO 65625-0543. A packing slip should be included with all shipments listing the sender's name, address, daytime phone number and description of defect. Your product will be put in first-class operating condition or replaced with a new part, and returned pre-paid.