



Mounting Instructions
11.9060 / 9260 Black LED Micro-Lite Kit
11.9070 / 9270 Aluminum LED Micro-Lite Kit
 (with 11.1005 or 11.1005SF LED Flasher)

A. Unpacking

Remove the (2) LED Micro-Lites, the LED Double Switch, the LED Flasher and all associated screws and locknuts.

B. Installation

1a. LED Installation With Bracket

Drill out the recessed hole Point A on each end of the LED Micro-Lites. (holes can only be seen from the bottom of the LEDs.) See Figure 1. Attach the brackets to their desired location using the (4) longer screws. Then place the Micro-Lites into the brackets and attach them using the shorter screws and locknuts. The (2) gaskets will not be needed.

NOTE: The recessed

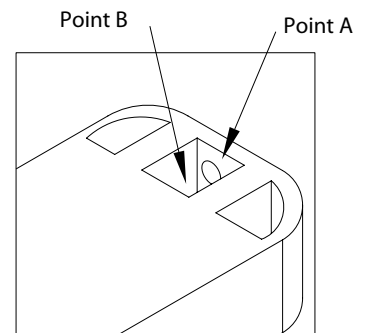
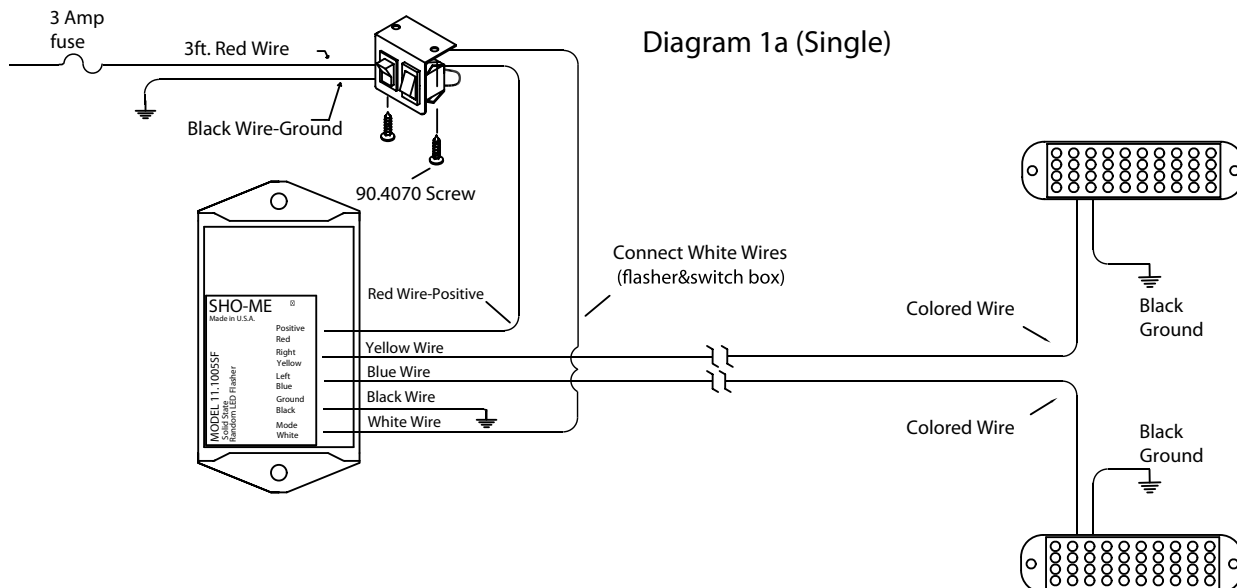

Figure 1

1b. LED Installation Without Bracket

Drill out the recessed hole Point B on each end of the LED Micro-Lites. (NOTE: The recessed holes can only be seen from the bottom of the LEDs.) See Figure 1. Drill the (4) holes on the mounting surface for the (2) LED Micro-Lites using an LED Micro-Lite as a guide. Place the (2) gaskets under the LED Micro-Lites. Attach the LED Micro-Lites using the (4) longer screws provided. The (2) brackets, (4) shorter screws and (4) locknuts will not be needed.

2. Mount the 11.1005SF LED Flasher using the (2) provided screws.
3. Mount the 11.1002 LED Double Switch using the (2) provided screws.
4. Connect the wires. (See Diagram 1a for single or 1b for dual.)
5. Connect switch wires to terminals on back of switch. (See Diagram 2 on next page.)
6. Connect the fused red wire to a +12V power source.



PRODUCTS COMPANY
 U.S. and Canada Toll Free Numbers
 E-mail: sales@able2products.com

804 East Hwy 248 Cassville, MO 65625
 Phone: 800-641-4098 FAX: 800-526-1240
 WEB: www.able2products.com

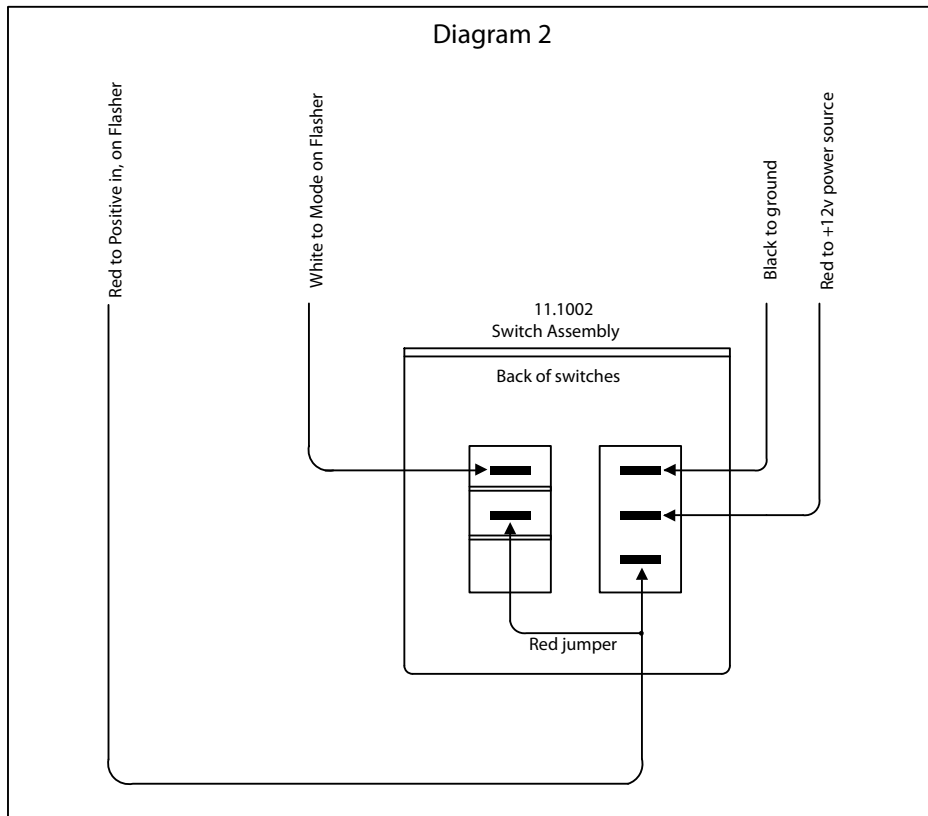

Warranty

Able 2 Products Company warrants each new product (except bulbs, strobe tubes, strobe power supplies and LED lights) to be free from defects in material and workmanship for a period of two years from the date of purchase. During this warranty period, the obligation of Able 2 is limited to repairing or replacing, as Able 2 may elect, any part or parts, which after examination by Able 2 are determined to be defective, when they are delivered pre-paid. This limited warranty does not cover travel expense, the cost of specialized equipment for gaining access to the product, or labor charges for the removal and re-installation of the product.

Able 2 Products Company shall not be liable for incidental or consequential damages, including but not limited to: Loss of use of vehicle, Rental of substitute vehicle, Loss of time, Loss of work, Inconvenience, Transportation expenses, Telephone, Lodging, Loss of revenue, Loss of and/or damage to personal property for or arising out of breach of any express or implied warranty of its products.

Use of lamp or other electrical load of a wattage higher than installed or recommended by the factory, or use of inappropriate or inadequate wiring or circuit protection causes this limited warranty to become void. Able 2 Products Company will in no way be liable for any loss of profits or any indirect or consequential damages arising out of any such defect in material and workmanship whether loss is due to negligence or breach of warranty. This limited warranty does not apply to shipping damage, accident, alteration, tampering, misuse or abuse and unauthorized service.

This limited warranty is expressly in lieu of all other express or implied warranties, including the implied warranty of merchantability and the implied warranty of fitness for a particular purpose, and of all other obligations or liabilities on the part of Able 2 Products Company. There are no warranties, unless expressed in authorized Able 2 literature, which extend beyond the description of the face hereof. No dealer, distributor, employee, or representative of the company is authorized to change this warranty in any way or to grant any other warranty.

Warranty Periods

11, 12 & 13 Series LED Products*	2 Years
*11.8400 Series LED Lights	1 Year
*12 Series Covert LEDs	1 Years
10 Series LED Lights	1 Years
09 Zoom Lite / 06 Series LED Lights	1 Year
All Other Products EXCEPT Bulbs (under normal use)	1 Years

NOTE: Halogen and Incandescent Bulbs are not covered by warranty