



MODEL NO. 11.8300
LED "By The Inch" Light

GENERAL INFORMATION:

NOTE: The 11.8300 Series LED "By The Inch" Lights must be wired to a flasher, such as 11.1005, 11.1005.SF. If light is connected to 12V (steady burn) it will over heat, and void warranty.

PRODUCT SPECIFICATIONS:

Optimum Input Voltage: +13.8 VDC
Operating Current: .04 amps per inch
Recommended Fuse: 3 amps

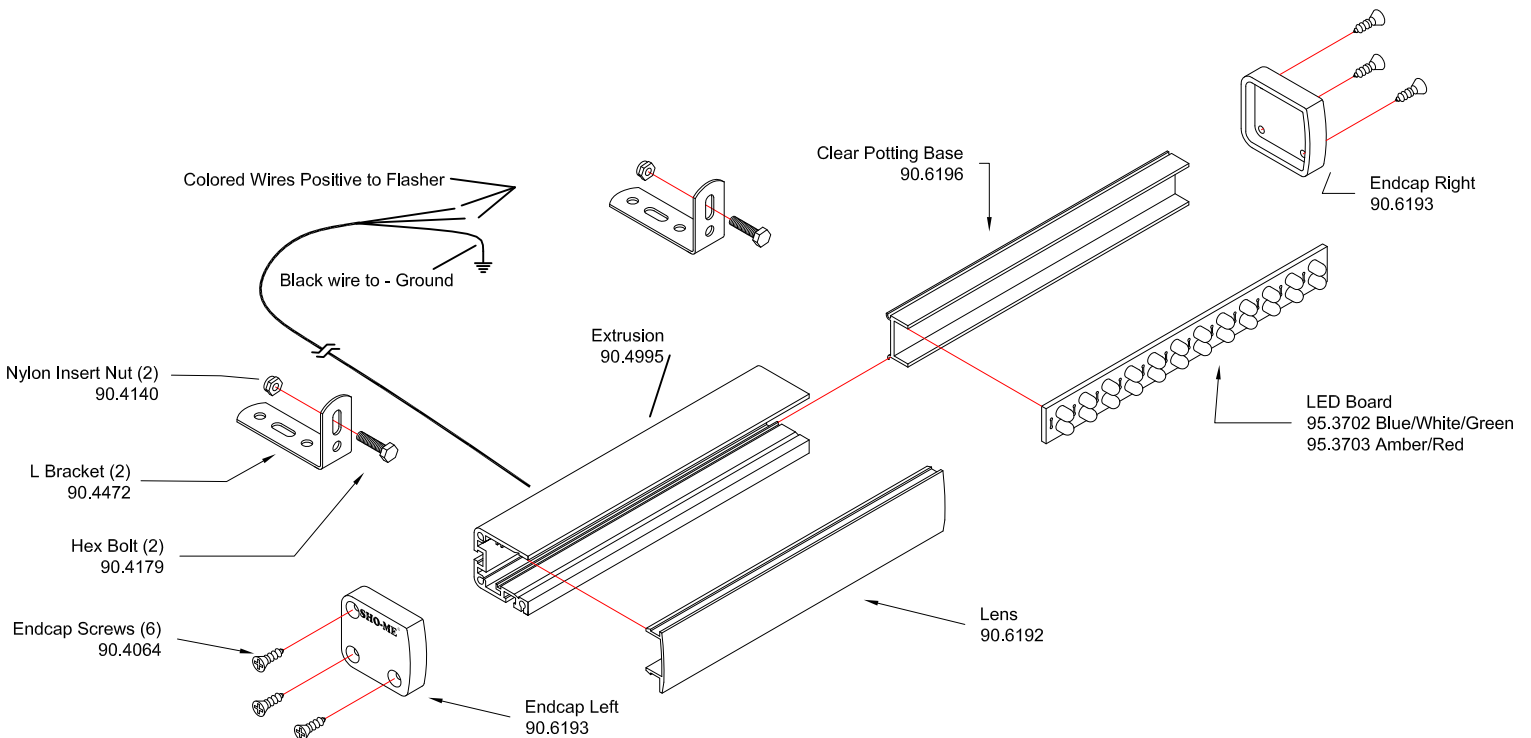

PRODUCTS COMPANY • 804 East Hwy. 248 • Cassville, MO 65625
U.S. and Canada Toll Free Numbers • Phone: 800-641-4098 FAX: 800-526-1240
E-mail: sales@able2products.com WEB: www.able2products.com

Installation Instructions

Slide the hex bolts provided into the t-slot as shown in the diagram below . The light can be mounted using the bottom or rear t-slots . Always mount with the bottom t-slot down, this is to allow any moisture that enters the light housing to drain properly. Drill two holes in your desired mounting surface, use the two hex nuts to mount the light to the mounting surface, be careful not to over tighten the hex nuts.

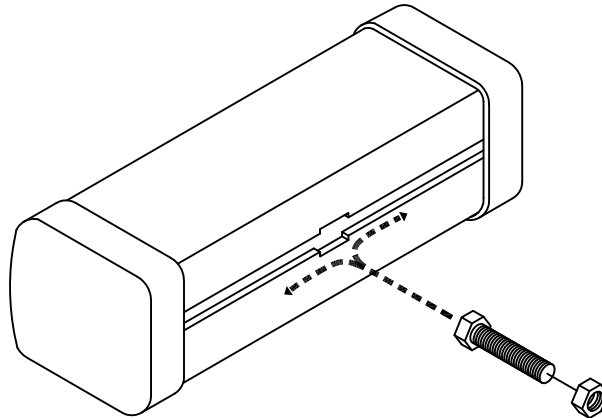

LIMITED WARRANTY

Able 2 Products Company warrants each new product (except bulbs, strobe tubes, strobe power supplies and LED Products) to be free from defects in material and workmanship for a period of two years from the date of purchase. During this warranty period, the obligation of Able 2 is limited to repairing or replacing, as Able 2 may elect, any part or parts, which after examination by Able 2 are determined to be defective, when they are delivered pre-paid. This limited warranty does not cover travel expense, the cost of specialized equipment for gaining access to the product, or labor charges for the removal and re-installation of the product.

Able 2 Products Company shall not be liable for incidental or consequential damages, including but not limited to: Loss of use of vehicle, Rental of substitute vehicle, Loss of time, Loss of work, Inconvenience, Transportation expenses, Telephone, Lodging, Loss of revenue, Loss of and /or damage to personal property for or arising out of breach of any express or implied warranty of its products.

Use of lamp or other electrical load of a wattage higher than installed or recommended by the factory, or use of inappropriate or inadequate wiring or circuit protection causes this limited warranty to become void. Able 2 Products Company will in no way be liable for any loss of profits or any indirect or consequential damages arising out of any such defect in material and workmanship whether loss is due to negligence or breach of warranty. This limited warranty does not apply to shipping damage, accident, alteration, tampering, misuse or abuse and unauthorized service.

This limited warranty is expressly in lieu of all other express or implied warranties, including the implied warranty of merchantability and the implied warranty of fitness for a particular purpose, and of all other obligations or liabilities on the part of Able 2 Products Company. There are no warranties, unless expressed in authorized Able 2 literature, which extend beyond the description of the face hereof. No dealer, distributor, employee, or representative of the company is authorized to change this warranty in any way or to grant any other warranty.

WARRANTIES:

All LED Products	5 Years
T Model & Potted Strobe Power Supplies	2 Years
All Other Strobe Power Supplies	5 Years
All Other Products EXCEPT Bulbs	2 Years (under normal use)
Strobe Tubes	1 Year (under normal use)

NOTE: Halogen and Incandescent Bulbs are not covered by warranty.

PRODUCT RETURNS

If a product must be returned, contact our factory by calling 1-800-641-4098 to obtain a Return Authorization Number (RA) before you ship the product. Write the RA Number clearly on the package and return it to Able 2 Products Company, P.O. Box 543, 804 E. Hwy. 248, Cassville, MO 65625-0543. A packing slip should be included with all shipments listing the sender's name, address, daytime phone number and description of defect. Your product will be put in first-class operating condition or replaced with a new part, and returned pre-paid.