

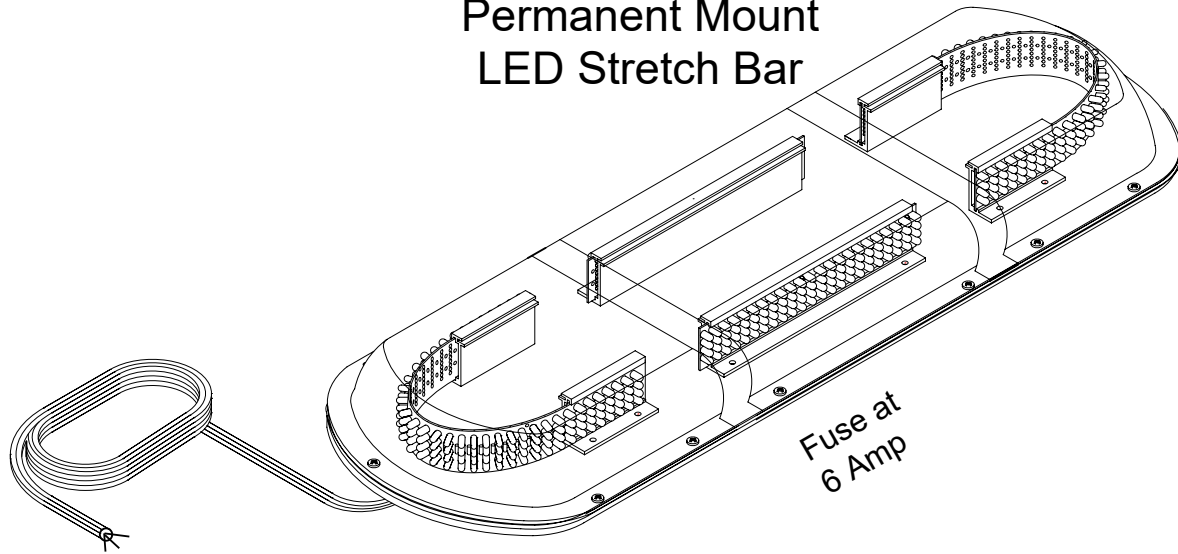

MODEL NO. 11.1227  
Permanent Mount  
LED Stretch Bar



### GENERAL INFORMATION:

The **SHO-ME**® LED Stretch Bar is equipped with a Solid State Flasher. The flasher has 7 flash patterns including random. To change flash patterns momentarily apply +12v to the white, mode wire. Each time +12v is applied, the flash pattern will change.

### FLASH PATTERNS

- |                                    |                                     |
|------------------------------------|-------------------------------------|
| 1. Quad Alternating - End/Middle   | 5. Sequential                       |
| 2. Quad Simultaneous               | 6. Double Alternating - Ends/Middle |
| 3. Quad Alternating                | 7. Random                           |
| 4. Single Alternating - End/Middle |                                     |

### INSTALLATION INSTRUCTIONS:

Determine location to mount your LED Stretch Bar. Attach bolts to bottom of your **SHO-ME**® LED Stretch Bar. Keep in mind airbag deployment area and any other obstacles. Run wire inside of vehicle and connect to switch. A momentary switch is required to change flash patterns.

If mounting this product requires drilling holes, the installer **MUST** be sure that no vehicle components or other vital parts could be damaged by the drilling process. Check both sides of the mounting surface before drilling begins. Also de-burr any holes and remove any metal shards or remnants. Install grommets into all wire passage holes.

Use only soap and water to clean the outer lens. Use of other chemicals could result in premature lens cracking and discoloration. Lenses in this condition have significantly reduced effectiveness. Inspect and operate this product regularly to confirm its proper operation and mounting condition. **Do not use a pressure washer to clean this product.**



**PRODUCTS COMPANY • 804 East Hwy. 248 • Cassville, MO 65825**  
**U.S. and Canada Toll Free Numbers • Phone: 800-641-4098 FAX: 800-526-1240**  
**E-mail: sales@able2products.com WEB: www.able2products.com**

## Parts List for 11.1227 LED Stretch Bar Permanent Mount

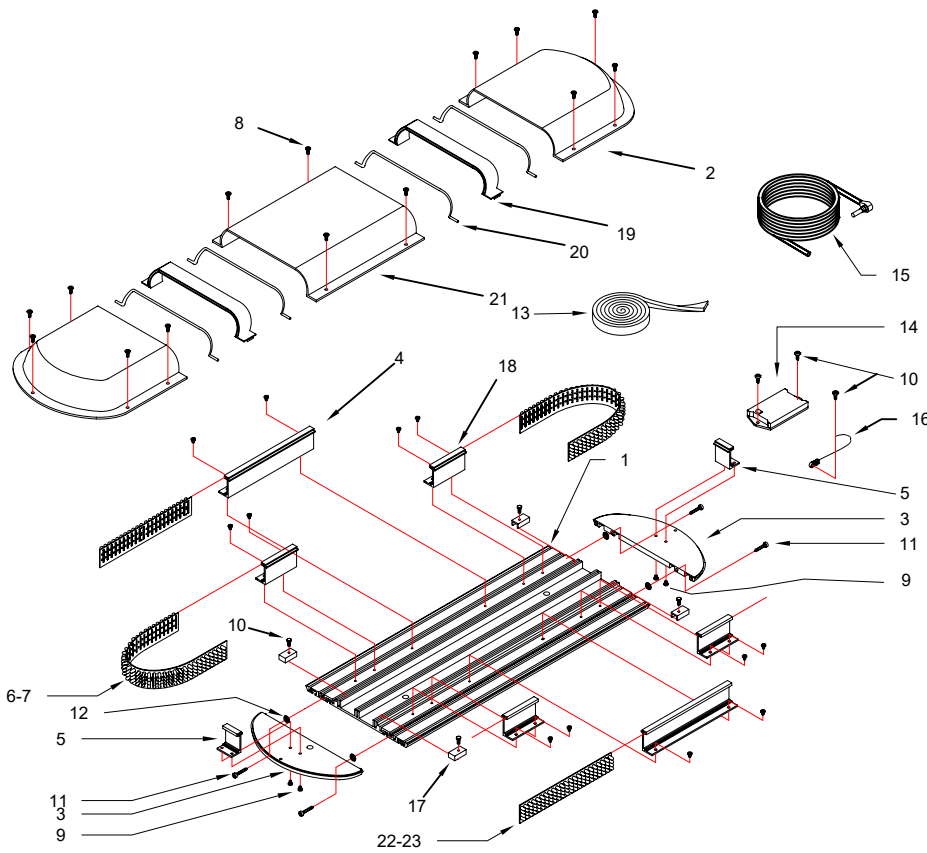

ITEM	MODEL NO.	DESCRIPTION	QTY
1	90.4986.000	21" Long Extrusion	1
2	90.6137.C00	Clear Lexan End Cover	2
3	90.6125.000	Black Plastic Endcaps	2
4	90.6938.000	Long Black Plastic LED mount	2
5	90.6931.000	Short Black Plastic LED mount	2
6	95.3750.(R/A)00	Red/Amber LED Board	
7	95.3751.BOO	Blue/White LED Board	2
8	90.4002.000	#01-0143 #8 x 1/ 2 812 Screw	14
9	90.4072.000	1/ 4" #6-32 Phillips	16
10	90.4772.000	8-32x3/ 8 Unslot HexHD SS	14
11	90.4021.SS	Endcap Self Tapping Screws	4
12	90.4530.000	#8 External Tooth Lock washer	4
13	90.6039.000	1/ 8" X 3/ 4" Bk Foam Adhesive 68"	1
14	11.1010.SF	LED Flasher 3-output	1
15	44.0183.000	Power Cord 4 Wire 15 ft	1
16	61.0651.000	7" Cable Ties	8
17	95.2120.000	Rubber Shim	4
18	90.6938.000	2-3/ 4" Cut Plastic	4
19	90.6138.000	Jointer Piece	2
20	90.6747.000	Rubber Gasket 1' ea	4
21	90.6136.000	Clear Lexan 10" Middle Lens	1
22	95.3750-1.(R/A)00	Red/Amber LED Board	
23	95.3751-1.BOO	Blue/White LED Board	2

### LIMITED WARRANTY

Able 2 Products Company warrants each new product (except bulbs, strobe tubes and strobe power supplies) to be free from defects in material and workmanship for a period of two years from the date of purchase. During this warranty period, the obligation of Able 2 is limited to repairing or replacing, as Able 2 may elect, any part or parts, which after examination by Able 2 are determined to be defective, when they are delivered pre-paid. This limited warranty does not cover travel expense, the cost of specialized equipment for gaining access to the product, or labor charges for the removal and re-installation of the product.

Able 2 Products Company shall not be liable for incidental or consequential damages, including but not limited to : Loss of use of vehicle, Rental of substitute vehicle, Loss of time, Loss of work, Inconvenience, Transportation expenses, Telephone, Lodging, Loss of revenue, Loss of and /or damage to personal property for or arising out of breach of any express or implied warranty of its products.

Use of lamp or other electrical load of a wattage higher than installed or recommended by the factory, or use of inappropriate or inadequate wiring or circuit protection causes this limited warranty to become void. Able 2 Products Company will in no way be liable for any loss of profits or any indirect or consequential damages arising out of any such defect in material and workmanship whether loss is due to negligence or breach of warranty. This limited warranty does not apply to shipping damage, accident, alteration, tampering, misuse or abuse and unauthorized service.

This limited warranty is expressly in lieu of all other express or implied warranties, including the implied warranty of merchantability and the implied warranty of fitness for a particular purpose, and of all other obligations or liabilities on the part of Able 2 Products Company. There are no warranties, unless expressed in authorized Able 2 literature, which extend beyond the description of the face hereof. No dealer, distributor, employee, or representative of the company is authorized to change this warranty in any way or to grant any other warranty.

<b>WARRANTIES:</b>	T Model & Potted Strobe Power Supplies	2 Years
	All Other Strobe Power Supplies . . . . .	5 Years
	All Other Products EXCEPT Bulbs. . . . .	2 Years (under normal use)
	Strobe Tubes . . . . .	1 Year (under normal use)
	NOTE: Halogen and Incandescent Bulbs are not covered by warranty..	

### PRODUCT RETURNS

If a product must be returned, contact our factory by calling 1-800-641-4098 to obtain a Return Authorization Number (RA) before you ship the product. Write the RA Number clearly on the package and return it to Able 2 Products Company, P.O. Box 543, 804 E. Hwy. 248, Cassville, MO 65625-0543. A packing slip should be included with all shipments listing the sender's name, address, daytime phone number and description of defect. Your product will be put in first-class operating condition or replaced with a new part, and returned pre-paid.