

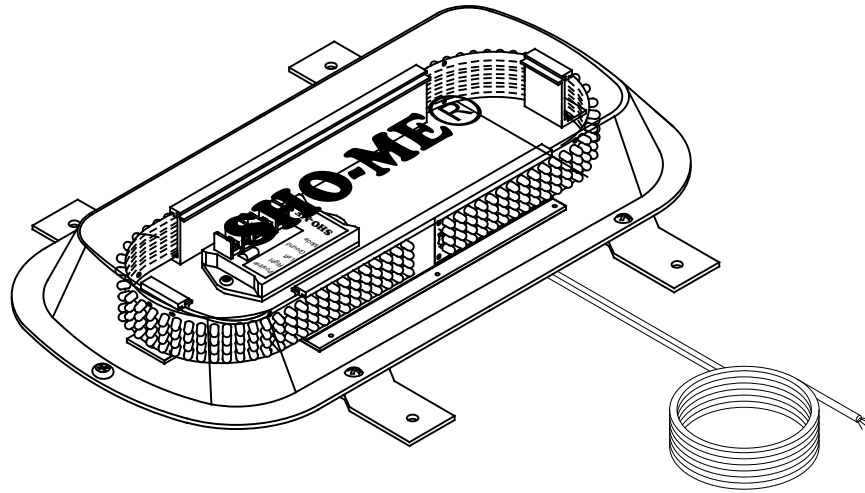

MODEL NO. 11.1200  
Permanent Mount Low Profile  
LED Mini Bar



**GENERAL INFORMATION:**

The **SHO-ME**® Low Profile LED Mini Bar is equipped with a Solid State Flasher. The flasher has 7 flash patterns including random. To change flash patterns momentarily apply +12v to the white, mode wire. Each time +12v is applied, the flash pattern will change.

**FLASH PATTERNS**

Double Alternating  
Quad Alternating  
Quint Alternating  
Mega Alternating

Double Simultaneous  
Quad Simultaneous  
Random

**INSTALLATION INSTRUCTIONS:**

Determine location to mount your Low Profile LED Mini Light Bar. Attach bolts to bottom of your **SHO-ME**® Low Profile LED Mini Bar. Keep in mind airbag deployment area and any other obstacles. Run wire inside of vehicle and connect to switch. A momentary switch is required to change flash patterns.

Connect the Green wire to +12v DC , Connect the Black wire to - Ground , Connect the White wire to momentary +12v .



**PRODUCTS COMPANY • 804 East Hwy. 248 • Cassville, MO 65625**  
**U.S. and Canada Toll Free Numbers • Phone: 800-641-4098 FAX: 800-526-1240**  
**E-mail: sales@able2products.com WEB: www.able2products.com**

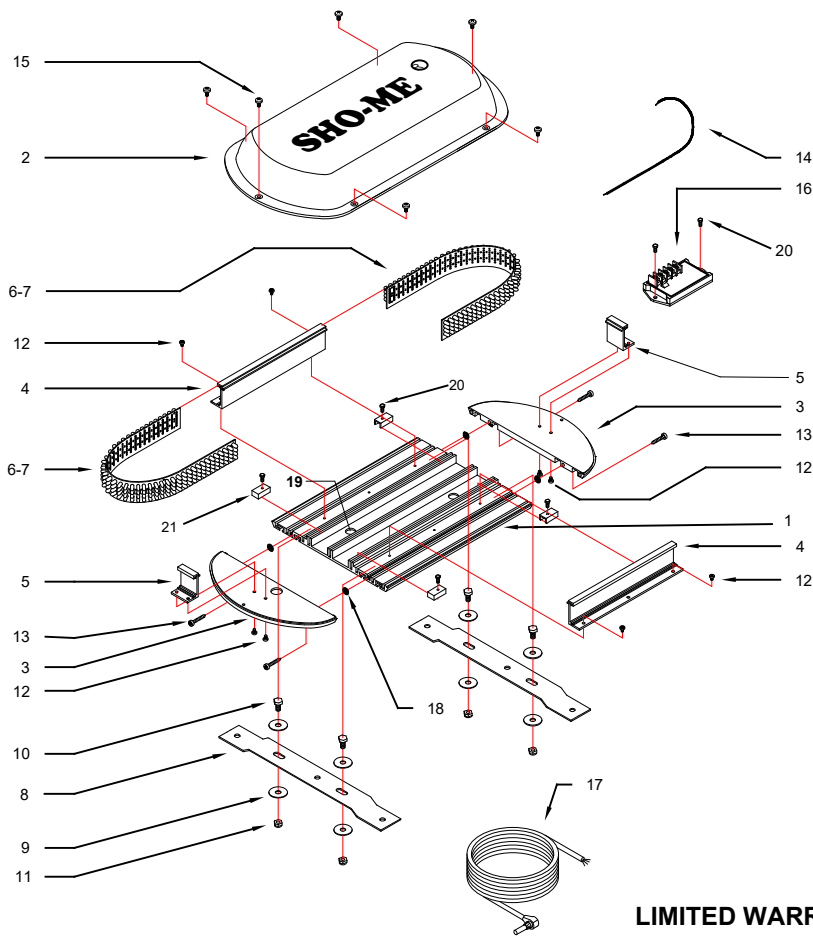

## Parts List for 11.1200 12v Low Profile LED Mini Bar Permanent

ITEM	MODEL NO.	DESCRIPTION	QTY
1	90.4986.000	Main Alu Extrusion	1
2	90.6127.C00	Clear Lexan Cover	1
3	90.6125.000	Black Plastic Endcaps	2
4	90.6938.000	Long Black Plastic LED mount	2
5	90.6931.000	Short Black Plastic LED mount	2
6	95.3750.(R/A)12v	Red/Amber LED Board	
7	95.3751.B0012v	Blue LED Board	2
8	90.4958.000	Brkts/Stealth 14 GA SS	2
9	90.4522.000	1/4 x 1 Fender Washer 18-8 SS	8
10	90.4081.000	1/4 -20 X 1/2 Hex Hd Bolt SS	4
11	90.4150.000	1/4-20 Nylon Insert L/N NTE SS	4
12	90.4072.000	1/4" #6-32 Phillips	8
13	90.4021.SS	Endcap Self Tapping Screws	4
14	41.0181.010	18 GA RV1 Wire 8" (specify color)	6
15	90.4027.SS	#8 X 3/8 Phillips Pan Head	6
16	11.1005.TSF 12v	Solid State Random LED Flasher	1
17	44.0183.000	Power Cable 4 Wire 12 ft	1
18	90.4530.000	#8 External Tooth Lock Washer	4
19	90.6027.000	Vent	2
20	90.4772.000	8-32X 3/8 Unslot HexHD SS	6
21	95.2120.000	Rubber Shim	4

### LIMITED WARRANTY

Able 2 Products Company warrants each new product (except bulbs, strobe tubes and strobe power supplies) to be free from defects in material and workmanship for a period of two years from the date of purchase. During this warranty period, the obligation of Able 2 is limited to repairing or replacing, as Able 2 may elect, any part or parts, which after examination by Able 2 are determined to be defective, when they are delivered pre-paid. This limited warranty does not cover travel expense, the cost of specialized equipment for gaining access to the product, or labor charges for the removal and re-installation of the product.

Able 2 Products Company shall not be liable for incidental or consequential damages, including but not limited to: Loss of use of vehicle, Rental of substitute vehicle, Loss of time, Loss of work, Inconvenience, Transportation expenses, Telephone, Lodging, Loss of revenue, Loss of and /or damage to personal property for or arising out of breach of any express or implied warranty of its products.

Use of lamp or other electrical load of a wattage higher than installed or recommended by the factory, or use of inappropriate or inadequate wiring or circuit protection causes this limited warranty to become void. Able 2 Products Company will in no way be liable for any loss of profits or any indirect or consequential damages arising out of any such defect in material and workmanship whether loss is due to negligence or breach of warranty. This limited warranty does not apply to shipping damage, accident, alteration, tampering, misuse or abuse and unauthorized service.

This limited warranty is expressly in lieu of all other express or implied warranties, including the implied warranty of merchantability and the implied warranty of fitness for a particular purpose, and of all other obligations or liabilities on the part of Able 2 Products Company. There are no warranties, unless expressed in authorized Able 2 literature, which extend beyond the description of the face hereof. No dealer, distributor, employee, or representative of the company is authorized to change this warranty in any way or to grant any other warranty.

<b>WARRANTIES:</b>	11, 12 & 13 Series LED Products*	2 Years
	*11.8400 Series LED Lights	1 Year
	*12 Series Covert LEDs	1 Years
	10 Series LED Lights	1 Years
	09 Zoom Lite / 06 Series LED Lights	1 Year
	All Other Products EXCEPT Bulbs (under normal use)	1 Years
	NOTE: Halogen and Incandescent Bulbs are not covered by warranty	

### PRODUCT RETURNS

If a product must be returned, contact our factory by calling 1-800-641-4098 to obtain a Return Authorization Number (RA) before you ship the product. Write the RA Number clearly on the package and return it to Able 2 Products Company, P.O. Box 543, 804 E. Hwy. 248, Cassville, MO 65625-0543. A packing slip should be included with all shipments listing the sender's name, address, daytime phone number and description of defect. Your product will be put in first-class operating condition or replaced with a new part, and returned pre-paid.